

ASAP LOCK



0082

EN 353-2: 2002

EN 12841: 2006 A



TPTC019/2011



XF 494-2004: FZL-Z-Q10/13
GB/T 24537-2009

Mobile fall arrester for rope
Antichute mobile sur corde

WARNING / ATTENTION

Activities involving the use of this equipment are inherently dangerous. You are responsible for your own actions and decisions.

Before using this equipment, you must:
- Read and understand all Instructions for Use.
- Get specific training in its proper use.
- Become acquainted with its capabilities and limitations.
- Understand and accept the risks involved.

FAILURE TO HEED ANY OF THESE WARNINGS MAY RESULT IN SEVERE INJURY OR DEATH.

Les activités impliquant l'utilisation de cet équipement sont par nature dangereuses. Vous êtes responsable de vos actes, de vos décisions et de votre sécurité.

Avant d'utiliser cet équipement, vous devez :
- Lire et comprendre toutes les instructions d'utilisation.
- Vous former spécifiquement à l'utilisation de cet équipement.
- Vous familiariser avec votre équipement, apprendre à connaître ses performances et ses limites.
- Comprendre et accepter les risques induits.

LE NON-RESPECT D'UN SEUL DE CES AVERTISSEMENTS PEUT ÊTRE LA CAUSE DE BLESSURES GRAVES OU MORTELLES.

PETZL.COM



Latest version
Dernière version



Other languages
Autres langues



Technical tips
Conseils techniques



PPE checking
Fiche de contrôle EPI

Warning symbols
Panneaux d'alertes



(1)



(2)



(3)



(4)

PETZL
FR-38920 Croles
Cidex 105A
PETZL.COM
ISO 9001
© Petzl



Sustaining our Community
Au service de la Communauté
FONDATION-PETZL.ORG

Traceability and markings Traçabilité et marquage

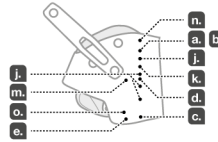
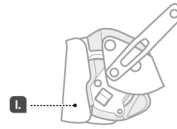

Apave Exploitation France SAS
6 Rue du Général Audran
92412 Courbevoie cedex
France
N°0082

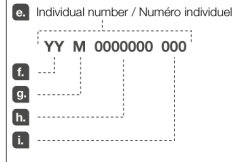

0120

This product is compliant with the Regulation 2016/425 on Personal Protective Equipment as brought into UK law and amended. Ce produit est conforme au règlement 2016/425 sur les équipements de protection individuelle tel que transposé en droit britannique et modifié.

Approved body performing the UKCA type examination and the production control of this PPE :

Organisme approuvé intervenant pour l'examen UKCA de type et le contrôle de production de cet EPI :

SGS United Kingdom Ltd
Inward Way
Rossmore Business Park
Ellesmere Port, Cheshire, CH65 3EN
United Kingdom
N° 0120

Authorized Representative in UK : PETZL UK Agency, Unit 3-7, Tebay Business Park, Old Tebay, Penrith, CA10 3SS, United Kingdom

China standards / 中国标准

When operating under the XF 494-2004 standard for firefighters, use only a 10-13 mm diameter Light or General Use kernmantle Life Safety Rope.

当在消防的XF 494-2004标准下使用时, 只能使用直径10-13 mm的轻型或通用夹芯生命安全绳索

1. Field of application Champ d'application



EN 12841 type A

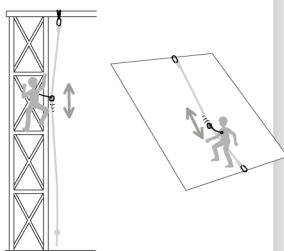

EN 353-2
GB/T 24537-2009

4. Compatibility Compatibilité

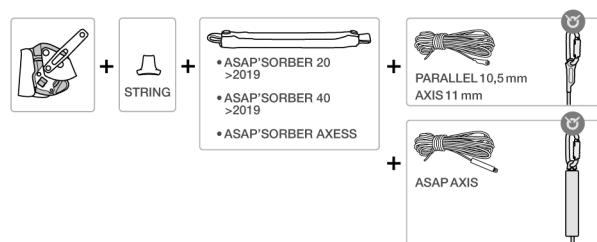
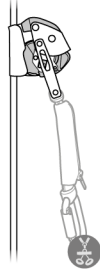
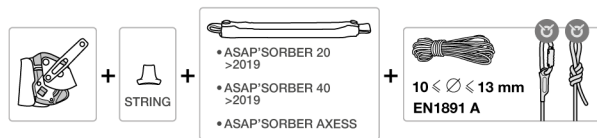
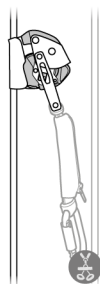

2. Nomenclature

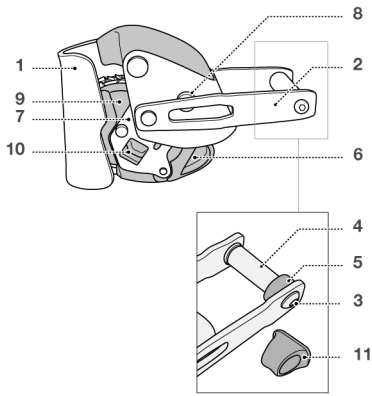

5. Working principle
Principe fonctionnement

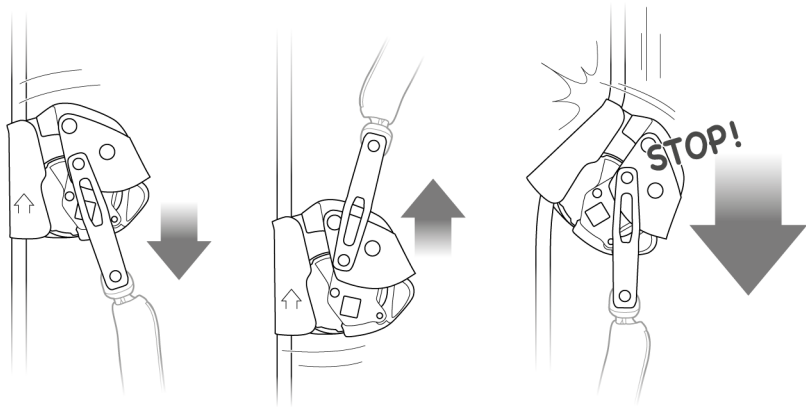

3. Inspection, points to verify
Contrôle, points à vérifier



Locking function
Fonction de blocage

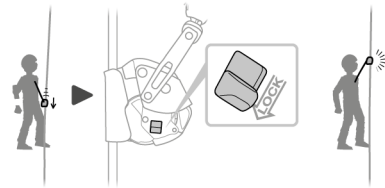

6. Installation and function test
Mise en place et test de fonctionnement

Preparation / Préparation

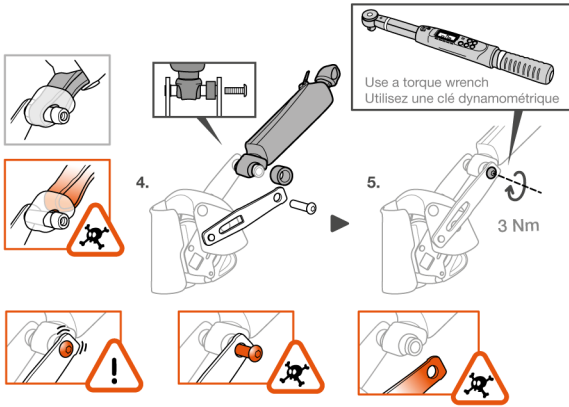
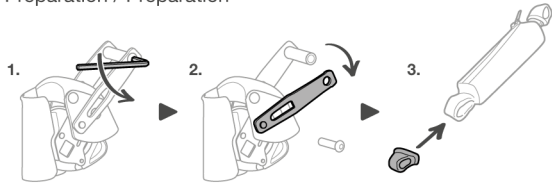

Attachment to the harness / Connexion au harnais

Frequent connection
Connexions fréquentes

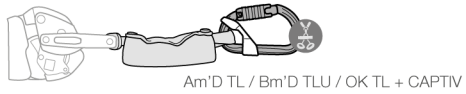

or /ou



or /ou

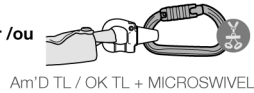

Semi-permanent connection
Connexions semi-permanentes

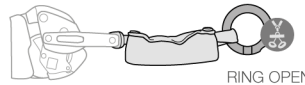

or /ou



Installation
Installation

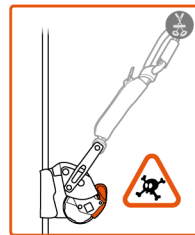
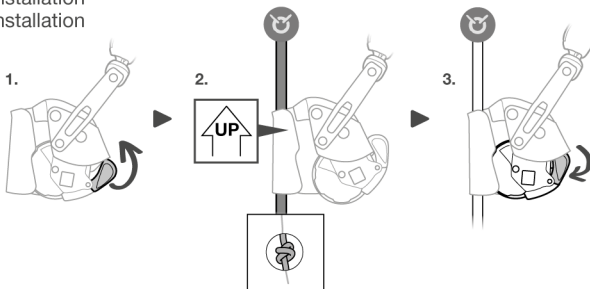

Test

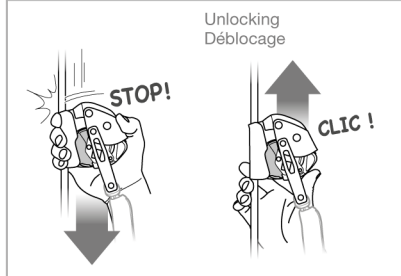

7. Precautions for use
Précautions d'utilisation

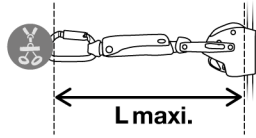

L maxi.

ASAP'SORBER 20 >2019	45 cm maxi.
ASAP'SORBER 40 >2019	65 cm maxi.
ASAP'SORBER AXESS	65 cm maxi.

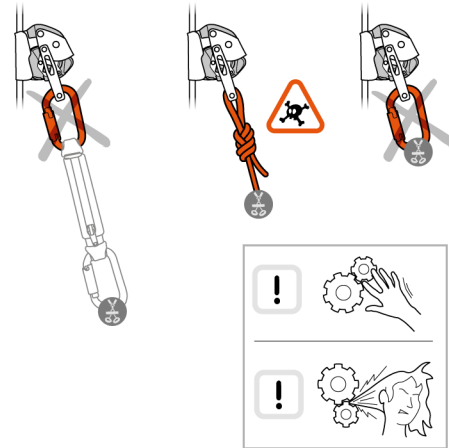
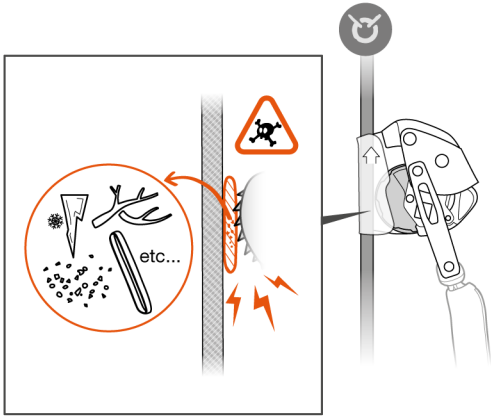
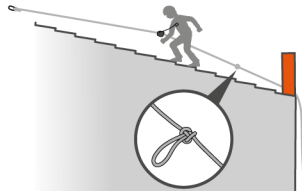
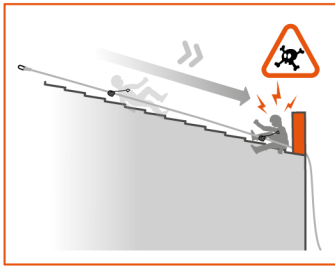
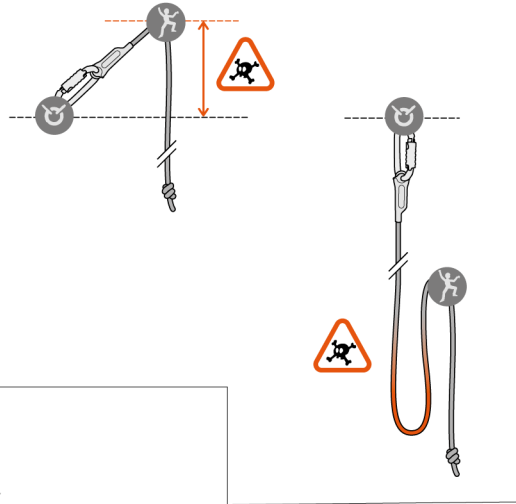

8. Clearance
Tirant d'air

	ASAP'SORBER 20 >2019	ASAP'SORBER 40 >2019	ASAP'SORBER AXESS

9. Cleaning (text part)
Nettoyage (partie texte)

10. Additional information
Informations complémentaires

A. Lifetime / Durée de vie unlimited / illimitée	B. Acceptable T° / T° tolérées - + 50°C / + 122°F - - 20°C / - 4°F
C. Precautions for use / Précautions d'usage 	
D. Cleaning / Nettoyage + 30°C maxi. / + 86°F maxi.	E. Drying / Séchage + 30°C maxi. / + 86°F maxi.
F. Storage - Transport / Stockage - transport + 30°C / + 86°F + 10°C / + 50°F	G. Maintenance Entretien
H. Modifications - Repairs Modifications - Réparations 	I. FAQ - Contact Questions - Contact

These instructions explain how to correctly use your equipment. Only certain techniques and uses are described.

The warning symbols inform you of some potential dangers related to the use of your equipment, but it is impossible to describe them all. Check Petzl.com for updates and additional information.

You are responsible for heeding each warning and using your equipment correctly. Any misuse of this equipment will create additional dangers. Contact Petzl if you have any doubts or difficulty understanding these instructions.

1. Field of application

Personal protective equipment (PPE) used for fall protection from height.

ASAP LOCK: mobile fall arrester for rope, with locking function

EN 12841 type A: rope adjustment device for the safety rope. Back-up device for a rope access system, to be used in conjunction with a type B or C progression device. EN 353-2: mobile fall arrester including a flexible safety line. Primary belay device in a fall-arrest system.

This product must not be pushed beyond its limits, nor be used for any purpose other than that for which it is designed.

Responsibility

WARNING

Activities involving the use of this equipment are inherently dangerous. You are responsible for your own actions, decisions and safety.

Before using this equipment, you must:

- Read and understand all Instructions for Use.
- Get specific training in its proper use.
- Become acquainted with its capabilities and limitations.
- Understand and accept the risks involved.

Failure to heed any of these warnings may result in severe injury or death.

This product must only be used by competent and responsible persons, or those placed under the direct and visual control of a competent and responsible person. You are responsible for your actions, your decisions and your safety and you assume the consequences of same. If you are not able, or not in a position to assume this responsibility, or if you do not fully understand the Instructions for Use, do not use this equipment.

2. Nomenclature

(1) Frame, (2) Clevis, (3) Screw, (4) Connection pin, (5) Spacer, (6) Safety catches, (7) Arm, (8) Arm axle, (9) Locking wheel, (10) Locking button, (11) STRING. Principal materials: aluminum alloy (frame, arm), stainless steel (locking wheel, clevis), polyester, nylon (ropes).

3. Inspection, points to verify

Your safety depends upon the integrity of your equipment.

Petzl recommends a detailed inspection by a competent person at least once every 12 months (depending on current regulations in your country, and your conditions of usage). **WARNING:** your intensity of use may cause you to inspect your PPE more frequently. Follow the procedures described at Petzl.com. Record the results on your PPE inspection form: type, model, manufacturer contact info, serial number or individual number, dates: manufacture, purchase, first use, next periodic inspection; problems, comments, inspector's name and signature.

Before each use

ASAP LOCK: verify that the absorber is correctly installed on the clevis, and that the screw is properly tightened.

Verify the absence of any cracks, nicks, deformation, wear, corrosion (on the frame, wheel, arm, clevis). Make sure the screw is securely tightened (correct installation, lack of play...).

Verify the condition of the safety catches, and that their return spring works.

Verify that the arm pivots on the axle, and that the return spring works. Verify that the locking wheel is clean and that the teeth are not worn out. **Warning:** if one or more teeth are missing, do not use the ASAP LOCK.

If the teeth are dirty, see the paragraph on Cleaning, maintenance. Verify that the locking wheel rotates smoothly, through one complete revolution in both directions.

Rope: check the condition of the rope according to the manufacturer's instructions. The rope must be retired if it has held a fall, if the core seems deformed, or if the sheath is damaged or stained.

During use

It is important to regularly monitor the condition of the product and its connections to the other equipment in the system. Make sure that all items of equipment are correctly positioned with respect to each other.

Beware of foreign objects that can prevent the locking wheel from pressing against the rope, or from turning. Protect your ASAP LOCK from splashes while working (paint, cement...). Make sure that the locking wheel is always engaged on the rope.

4. Compatibility

Verify that this product is compatible with the other elements of the system in your application (compatible = good functional interaction).

Equipment used with your ASAP LOCK must meet current standards in your country (e.g. EN 361 harnesses in Europe...).

Harness:

Connect your ASAP LOCK's energy absorber to a fall-arrest attachment point on your harness.

Energy-absorbing lanyard:

Use the ASAP LOCK only with compatible Petzl energy absorbers:

- ASAP'SORBER 20 and 40.
- ASAP'SORBER AXESS.

The energy absorber must not be extended (one connector maximum: 12 cm maximum length).

Rope, EN 12841 type A usage:

Use the ASAP LOCK with 10-13 mm EN 1891 type A low stretch kernmantle ropes.

Ropes tested during the EU EN 12841 type A certification:

- Petzl CLUB 10 mm.
- Teufelberger KM III 13 mm.

Rope, EN 353-2 usage:

Use the ASAP LOCK only with the ropes tested during the EU EN 353-2: 2002 certification:

- Petzl PARALLEL 10.5 mm.
- Petzl AXIS 11 mm.
- Petzl ASAP'AXIS 11 mm.

5. Working Principle

At moderate speeds, the locking wheel turns freely in both directions. When a rapid downward movement occurs, the locking wheel stops rotating and the rope is blocked by being pinched between the wheel and the frame.

Locking function: the integrated locking function allows the user to immobilize the device in order to reduce the length of a fall.

6. ASAP LOCK setup, and function test

Preparation:

Use only your ASAP LOCK's original screw. Apply thread-lock to the screw before assembly.

Install the energy absorber and close the clevis. Tighten, check the correct positioning of the axle and the screw tightness.

To ensure proper performance of your device, the screw must be correctly installed and tightened to the indicated torque. Using a torque wrench is the only way to verify that the tightening torque is correct.

Connection to the harness:

Frequent connection: use a TRIACT-LOCK EN 362 locking connector with a system that helps keep it positioned in the major axis (STRING, CAPTIV...).

Semi-permanent connection: use a semi-permanent connector, closed with a tool (RING OPEN, SWIVEL OPEN, quick link...).

Installation: open the safety catches to place the rope in the frame, close the catches to engage the locking wheel on the rope.

Warning: the ASAP LOCK is a directional device and locks in only one direction.

Danger of death if the ASAP LOCK is positioned upside down on the rope.

Perform a function test for each installation. **Unlocking:** after the function test, unlock the wheel to enable normal movement on the rope.

Locking function: use the wheel's locking button to prevent the ASAP LOCK from moving downward on the rope. **Warning:** in the case of accidental suspension on a locked ASAP LOCK, it cannot be unlocked while under load.

7. Precautions for use

Possible to create a travel-stop by tying a knot in the rope.

As you progress, regularly check that the rope is sliding properly in the ASAP LOCK to avoid creating a loop of slack that could increase the potential fall distance.

A dynamic overload can damage the rope. If the ASAP LOCK's rope is loaded, the user must be equipped with another back-up system.

Usage on an incline:

WARNING: in the event of a slow slide on a low-angle roof, for example, the ASAP LOCK may not activate immediately. Be sure to tie a stopper knot in the rope if there is a risk of hitting an obstacle.

8. Clearance

Clearance is the minimum amount of clear space below the user that prevents the user from hitting an obstacle in the event of a fall.

Clearance takes into account:

- The length of the fall.
 - The ASAP LOCK's stopping distance.
 - The tearing length of the energy absorber.
 - The average height of the user.
 - A safety margin of 1 meter.
- The rope's elasticity (E) varies according to the situation and must be added to your clearance calculation.

For more information, see the ASAP LOCK technical tips at Petzl.com.

The values presented are based on theoretical estimations and on fall tests using a rigid mass.

In a fall-arrest system, take into account the length of any connectors that will have an effect on the fall distance.

9. Cleaning, maintenance

Avoid getting any liquid inside the locking wheel's mechanism.

To clean the locking wheel teeth, using a solvent is not recommended, but is possible if applied with a brush, taking care to avoid getting any solvent in the mechanism.

10. Additional Information

This product meets the requirements of Regulation (EU) 2016/425 on personal protective equipment. The EU declaration of conformity is available at Petzl.com.

- You must have a rescue plan and the means to rapidly implement it in case of difficulties encountered while using this equipment.
- The anchor point for the system should preferably be located above the user's position and should meet the requirements of the EN 795 standard (12 kN minimum strength).
- In a fall-arrest system, it is essential to check the required clearance below the user before each use, in order to avoid hitting the ground or an obstacle in the event of a fall.
- Make sure that the anchor point is correctly positioned, in order to limit the risk and the length of a fall.
- A fall-arrest harness is the only device allowable for supporting the body in a fall-arrest system.
- When using multiple items of equipment, a dangerous situation can arise in which the safety function of an item of equipment can be affected by the safety function of another item of equipment.
- **WARNING - DANGER:** ensure that your products do not rub against abrasive or sharp surfaces.
- Users must be medically fit for activities at height. **WARNING:** inert suspension in a harness can result in serious injury or death.
- The Instructions for Use for each item of equipment used in conjunction with this product must be followed.
- The Instructions for Use must be provided to the user of this equipment, in the language of the country where the equipment is used.
- Keep the Instructions for Use in a permanent file for reference after removing them from the equipment.
- Make sure the markings on the product are legible.

When to retire your equipment:

WARNING: an exceptional event can lead you to retire a product after only one use, depending on the type and intensity of usage and the environment of usage (harsh environments, marine environments, sharp edges, extreme temperatures, chemicals...).

A product must be retired when:

- It has exceeded its lifespan.
- It has been subjected to a major fall or load.
- It fails to pass inspection. You have any doubt as to its reliability.
- You do not know its full usage history (e.g. an illegible product marking).
- When it becomes obsolete due to changes in legislation, standards, technique or incompatibility with other equipment...

Destroy these products to prevent further use.

Icons:

A. Unlimited lifespan - B. Acceptable temperatures - C. Usage precautions - D. Cleaning/disinfection - E. Drying - F. Storage/transport - G. Maintenance - H. Modifications/repairs (prohibited outside of Petzl facilities, except replacement parts) - I. Questions/contact

3-year guarantee

Against any material or manufacturing defect. Exclusions: normal wear and tear, oxidation, modifications or alterations, incorrect storage, poor maintenance, negligence, uses for which this product is not designed.

Warning symbols

1. Situation presenting an imminent risk of serious injury or death. 2. Exposure to a potential risk of accident or injury. 3. Important information on the functioning or performance of your product. 4. Equipment incompatibility.

Traceability and markings

a. Meets PPE regulatory requirements. Notified body performing the EU type examination - b. Number of the notified body responsible for the production control of this PPE - c. Traceability: datamatrix - d. Rope compatibility - e. Serial number - f. Year of manufacture - g. Month of manufacture - h. Batch number - i. Individual identifier - j. Standards - k. Read the Instructions for Use carefully - l. Model identification - m. Nominal maximum load - n. ANSI/ASSP certification body - o. Manufacturer address

